

# Drumbo Soap Box Derby Saturday August 20<sup>th</sup> 2016

## Hosted By Lions and Fire Fighters

### General Instruction:

Since ramp starting will be used, you are advised to build your car so that it conforms to the minimum and maximum dimension.

The racers must be between the ages of 7 to 77

Your car will be issued an officially approved sticker after it has passed inspection. No alterations to your car will be allowed after the sticker is issued.

In all cases where a decision is required, the race Judge's decision will be made (Gideon Kleinsasser). If this does not resolve any issue, the Grand Race Marshall will be asked to decide and it will be final.

It is expected that all drivers and people in their pit crews will act in a sportsmen like manner at all times. Anyone who does not uphold the requests of the race officials may be expelled from the race.

There will be volunteers along the race way to help the racers if needed and to make sure the race is fair.

There will be two volunteers from the Fire Department to ensure safe starts off the ramp.

There will be two volunteers at the finish Line. Lions Club (Drumbo or Plattsville Lions)

First car the cross the finish line wins the heat.

If your car needs repair during the races, and you are called to race, you will be given one run's grace

Of 10 Minutes. But you must be ready when your number is called for a second time, or be eliminate.

This action must be taken as to not slow the race schedule

On Race day, the Grand Race Marshall has the authority to reject and eliminate from the race any vehicle which he believes is unsafe, or does not conform to the specifications.

Entries may be disqualified for unsportsmanlike behavior of driver or pit crew.

Protective head gear must be worn during each race. We strongly recommend a snowmobile, bicycle or motorcycle helmet. Rules of the race will be located on a board at the registration table on the day of the race.

# Drumbo Soap Box Derby Saturday August 20<sup>th</sup> 2016

## Hosted By Lions and Fire Fighters

### The Vehicle

To maintain fairness and family fun we recommend home built soapbox cars. No professional Entries in order to ensure a competitive atmosphere, the vehicles must conform to the following specifications. The following rules are to ensure better safety of the racers. Some rules that follow are that of the National Soap Box Racing Association.

The total receipted value of the vehicle (including the wheels cannot exceed \$250.00

Receipts may be requested for all purchases or donations put towards or for the construction of the vehicle.

The overall length will be no longer than 80 inches.

Minimum wheelbase of 48 inches the distance between the centers of the front and rear wheels of the left and right wheels. Front and rear axles must be the same width the axle width between the wheels

The minimum ground clearance of 3 inches and a maximum of 7' when the driver is seated in the vehicle the axils must be between a minimum of 30" and no more than 36' maximum. No exceptions

Foot operated brakes only. The steering apparatus must be enclosed as nearly as possible by the body of the vehicle and shall include limit devices which prevents the front wheels from rubbing the body of the frame. The body of the vehicle must be made of wood, fiberglass or plastic. It will not enclose the seating area and must permit free use of hands and arms. (No enclosed cockpits)

The head cannot be confined by the vehicle

No sharp edges or protruding objects on exterior or interior.

The soapbox height will be no taller than 28' inches from the ground.

Safety Inspections and qualifications will be held on the corner of Jarvis and Mechanic Street. 8:00 am until 8:50. (Blandford Blenheim Fire Fighters)

### **Safety Inspections and qualification of the vehicle, inspector will inspect the following**

Brakes (a test will be performed) for a short and controlled stop.

Strength of frame

Fastening and securing of the axels and wheels

Steering assembly (must have steering stops which prevent wheel lock up the frame or body) of car.

No sharp edges or Objects

No alterations to wheels or bearings will be allowed, including excess us of oil.

Any car that does not comply will have to be altered before they can race.

The Driver of the car must be in attendance of the safety, inspection and qualifications.

Before the race the Firefighter will check helmet for proper fitting

Proof of age- weight of driver and car (must not exceed 250 pounds)

Alterations as determined at safety inspection and qualification must be completed and re-tested.

The Race

# Drumbo Soap Box Derby Saturday August 20<sup>th</sup> 2016

## Hosted By Lions and Fire Fighters

### **The Course will be held on Mechanic Street between Duke and Taylor.**

You are advised to be at the staging area with your car by 8:00 am on Saturday August 20<sup>th</sup> 2016 for inspection and registration. Corner of Jarvis and Mechanic Street.

All cars will be started from a ramp. False starts will be called only if the starting stages feel an advantage from the start was made. Each car will have at least two runs, each time changing Lanes when possible.

The order of the first round race shall be determined by a draw. After the first round of racing, losers will race against losers and winners will race against winners in a double elimination fashion. Each driver will continue to race until/he/she has lost twice. Drivers with their cars will be matched for each race by draw.

Cars will be returned after each race by a truck and trailer to the staging and pit area.

Drivers and cars must be ready to race when their names is drawn.

If an odd number of cars are left to race, the odd car will be entered into the last race in that particular round.

Any further instructions will be made on race day at the drivers meeting area prior to race time.

The race will begin at 9:30 am

### **Final Note**

Changes to car: Absolutely no changes to be made to any car once it has been inspected and received and approval Sticker.

Anyone found making changes to his/her car during the course of the race will automatically disqualified and eliminated from the remainder of the race.

- A) Removal of or addition to weight of the car – ex-Sandbagging
- B) B) Removal of or modification to body panels or structures of car
- C) Changing to a second set of wheels.
- D) In the event of damage to a car, for example where the driver hits a curb, repairs can be made to the extent that as little work as necessary is done to allow the car to continue racing, and it must pass safety inspection before being allowed to continue

Conduct; we would appreciate both drivers and pit crew including parents to act in a sportsmanlike manner at all times. Race officials will attempt to make sure that all vehicles are running according to regulation and that all races are run in a fair manner. Race official's decisions are final. Race officials have the right to disqualify driver, vehicle or pit crew at any time for inappropriate behavior.

# Drumbo Soap Box Derby Saturday August 20<sup>th</sup> 2016

## Hosted By Lions and Fire Fighters

### Registration Form 2016

Name of Driver \_\_\_\_\_

Parent or Guardian \_\_\_\_\_

Address \_\_\_\_\_

Town/City \_\_\_\_\_ Postal Code \_\_\_\_\_

Telephone Number \_\_\_\_\_ Email Address \_\_\_\_\_

#### Parent or Guardian Waiver

My son/daughter has been read to them b myself the instructions issued for this event. He/she agrees to compare according to these instructions and any others that may be issued. I hereby grant permission for my son/daughter to participate in the Drumbo Soap Box Derby and in consideration of the acceptance of this entry. I understand that Drumbo Lions, Plattsville Lions and the township of Blandford Blenheim and or their respective officer's agent's volunteers or representations cannot be held responsible for any damage or injuries caused to by my son/daughter during the course of this event not withstanding that the same may have been contributed to by the above mentioned persons. I feel that my child can safely handle a soap box car.

Date: \_\_\_\_\_ this Day \_\_\_\_\_ of \_\_\_\_\_ 20 \_\_\_\_\_

Note: The cost of participating in this race with a car is \$15

The coast of Participating without a car is \$25 dollars

Amount Paid \_\_\_\_\_

# Drumbo Soap Box Derby Saturday August 20<sup>th</sup> 2016

Hosted By Lions and Fire Fighters

## Soap Box Derby Car Specifications

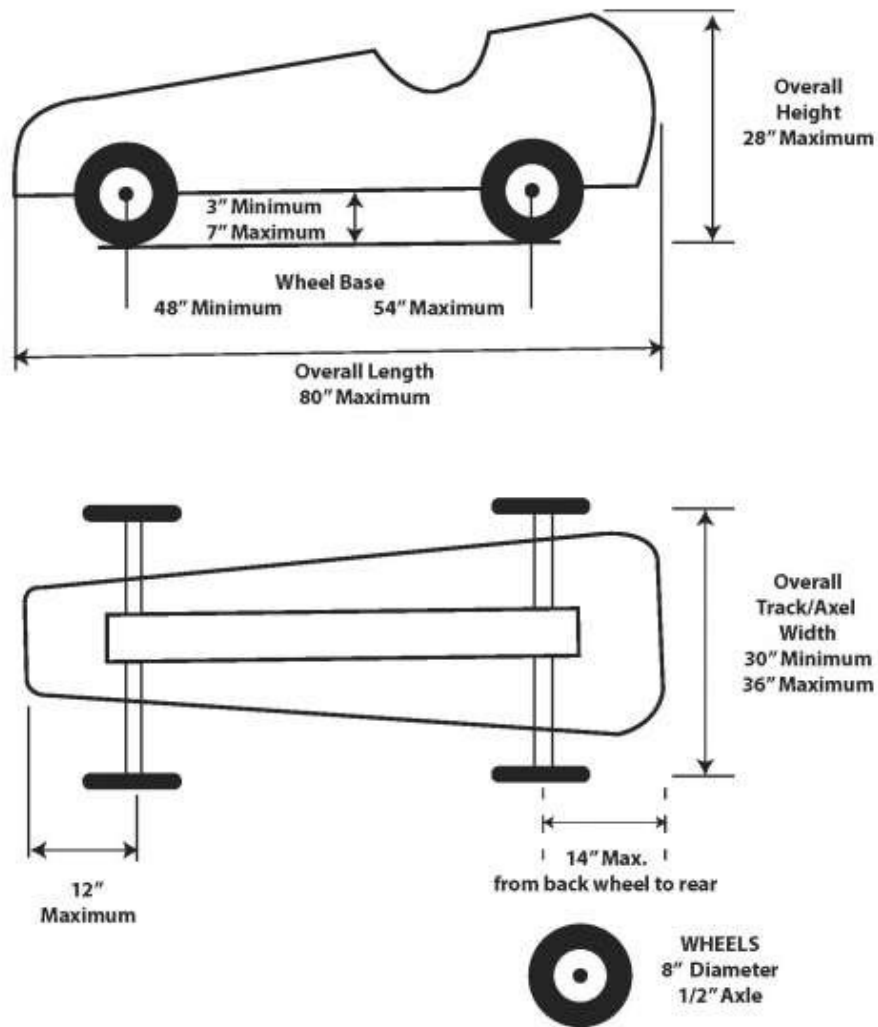

Official Soap Box wheels which are larger will be allowed in the race.

# Drumbo Soap Box Derby Saturday August 20<sup>th</sup> 2016

Hosted By Lions and Fire Fighters

## Suggested Steering and Braking Mechanisms

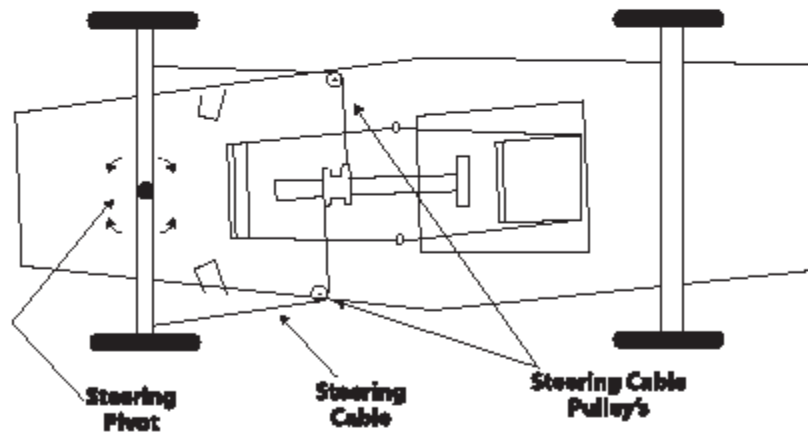
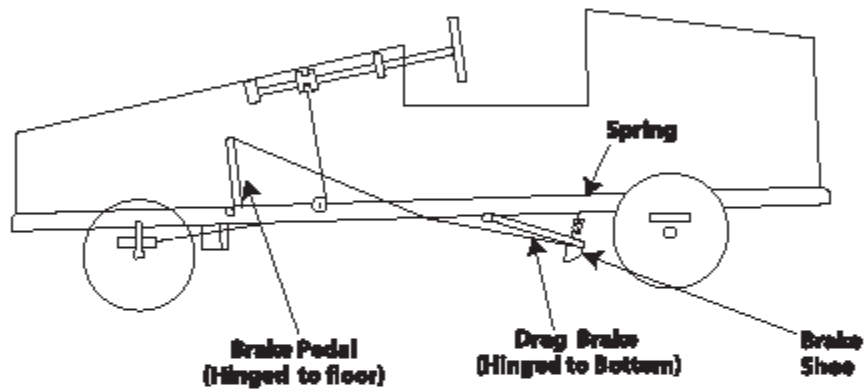

# Drumbo Soap Box Derby Saturday August 20<sup>th</sup> 2016

Hosted By Lions and Fire Fighters

